

CLASSE

Owner's Manual
Delta MONO
Monaural Amplifier

Contents

Welcome to the Classé family	3
Unpacking and Placement.....	4
Special Design Features	6
Front Panel.....	7
Rear Panel.....	9
Installation	15
CAN-Bus.....	17
Care and Maintenance.....	20
Troubleshooting	21
Specifications.....	23
Dimensions.....	25

Welcome to the Classé family

Congratulations on your purchase of a Classé amplifier. It is the result of many years of design experience, and we are sure that you will enjoy it for many years to come.

We value our relationship with our customers. Please allow us to stay in touch with you by registering now. Doing so will enable us to let you know about any possible future upgrades or updates that might become available for your Classé component.

You can register online at <https://classeaudio.com>.

Please take a few moments now to register your new Classé amplifier and record your serial number for future reference

a word about installation

Every effort has been made to make the Classé Delta MONO simple and straightforward to install and use.

It may be placed on a shelf, in a cabinet or on the floor near the speaker(s). As with all amplifiers, the Delta MONO generates some heat and care should be taken to allow adequate ventilation.

The size and shape of your room, its acoustics, and the associated equipment you have chosen to use with your amplifier all influence the performance of your system.

For this reason, we strongly encourage you to have your system installed and calibrated by your dealer, whose experience, training, and specialized equipment can make a profound difference in the final performance of the system.

Unpacking and Placement

unpacking your amplifier

Carefully unpack your power amplifier according to the supplied instructions, and remove all accessories from the carton. Please take care when lifting the amplifier, as it is extremely heavy with weight somewhat concentrated near the front right corner.



Important!

Keep all packing materials for future transport of your Classé amplifier. Shipping your new component in anything other than its purpose-designed packing material may result in damage that is not covered by the warranty.



Important!

Remove the protective film from the meter lens slowly to reduce the chance that static will build up inside, causing a deflection of the meter's pointer. If this happens, the pointer may settle to its nominal zero position over a short time on its own, but an anti-static wipe has been included in the accessories pack which can be used to discharge the static. Gently swiping it across the lens surface should remove any built up static charge from the meter assembly.

placement

Many installations will utilize an equipment rack, although a shelf, a cabinet or the floor near the speaker(s) are acceptable alternatives. In any case, take care to position it well away from source components and preamp/processors, which may be sensitive to the amplifier's electromagnetic fields.

Note that adequate clearance for the AC cord and connecting cables must be left behind the amplifier. We suggest leaving six inches (15 cm) of free space behind your power amplifier to allow all cables sufficient room to bend without crimping or undue strain.

unit's temperature

An important note about letting the unit come to room temperature:

The amplifier has built-in circuitry that will prevent it from being powered on if it is too cold. If the amp has been delivered on a cold day it should be allowed to acclimate to room temperature before being plugged in.

ventilation

Your Classé power amplifier generates a certain amount of heat in the course of normal operation. Avoid placement on soft surfaces that would restrict airflow around the unit (such as plush carpeting). Leave at least two inches (5 cm) of clearance in front and above the amplifier and six inches (15 cm) behind the amplifier to allow the active cooling system to function properly. If installing the amplifier in a cabinet, make sure that an opening at least 4" x 4" (10 cm x 10 cm) is provided opposite the fan exhaust area on the amplifier rear panel.

custom installations

Drawings are included in this manual to facilitate special installations and custom cabinetry (see the section *Dimensions*). Contact your Classé dealer for more information.

serial number

The serial number for your power amplifier is found on the rear of the unit. Please note and record this number on the page entitled *Important Safety Instructions* for your future reference.

operating voltage

The operating voltage of your Delta MONO is indicated on the rear of the unit. Do NOT connect the amplifier to AC mains power of different line voltage.



Warning:

There are no user-serviceable parts within the unit. Please refer any problems to an authorized Classé service center.

The amplifier can easily be powered by a normal 15 or 20-amp AC mains line. If other devices are also powered from the same AC line, their additional power consumption should be taken into account.

warm up/break-in period

Your new Classé power amplifier will deliver outstanding performance immediately. However, you should expect to hear it improve somewhat as it reaches its normal operating temperatures and its various components “break-in.” It has been our experience that the greatest changes occur within the first 72 hours, as the amplifier reaches thermal equilibrium and the capacitors fully form. After this initial break-in period, the performance of your new amplifier should remain quite consistent for years to come.

please read this manual...

Please take a few minutes to review this manual, and to familiarize yourself with your new amplifier. We understand that you are anxious to plug everything in and get started. However, reading this manual and following the advice it gives will ensure that you get all the benefits you deserve from having purchased such a fine piece of equipment.

Special Design Features

highly refined circuit design

This Classé amplifier utilizes our latest technology, implemented with the highest quality parts. A combination of careful part selection and circuit layout combined with an extended class A operating area enables superior performance under all conditions. It delivers enormous power into low-impedance loads and achieves extremely low distortion throughout the audio band, most notably maintaining its low-distortion profile even at high frequencies. The result is an engaging sound without listener fatigue that will lead to countless hours of listening enjoyment.

extensive listening tests

Excellent measured performance is to be expected in world-class products, and Classé products deliver that performance. However, experience has shown that technical excellence alone is insufficient to guarantee subjectively musical results.

For this reason, all Classé products are laboriously fine-tuned during the development process by carefully controlled listening tests. Our ears are still some of the finest test instruments available, and nicely complement even the best engineering test equipment. We rely on careful listening tests, which we view as a necessary complement to the solid engineering you should rightly expect from Classé.

extraordinary longevity

The Classé Design team has accumulated vast experience in what works well over the long term.

By using only the highest quality parts to begin with, and then using them in an informed way as a result of both accelerated aging tests and actual long-term experience, we are able to design and manufacture products which we are confident will stand the test of time.

We are confident that your new Classé amplifier will give you many years of trouble-free reliability and musical enjoyment, just as previous Classé products have given their owners.

robust protection

Finally, your new Classé amplifier incorporates a variety of protection circuits, all designed to protect both the amplifier and your loudspeakers against dangerous fault conditions. Significantly, these protection circuits do not intrude upon or limit the normal performance of the amplifier; rather, they simply put the amplifier into *protection* mode when confronted with abnormal conditions. These conditions include:

- output overload and short circuit protection
- DC offset
- excessive operating temperatures

Some conditions, such as DC offset, may be corrected up to a point automatically in the amplifier while others will result in the amplifier switching itself off. In such a case, the **Standby LED** status indicator will blink red until the fault can be righted and the amplifier is reset by pressing and holding the standby button for at least five seconds.

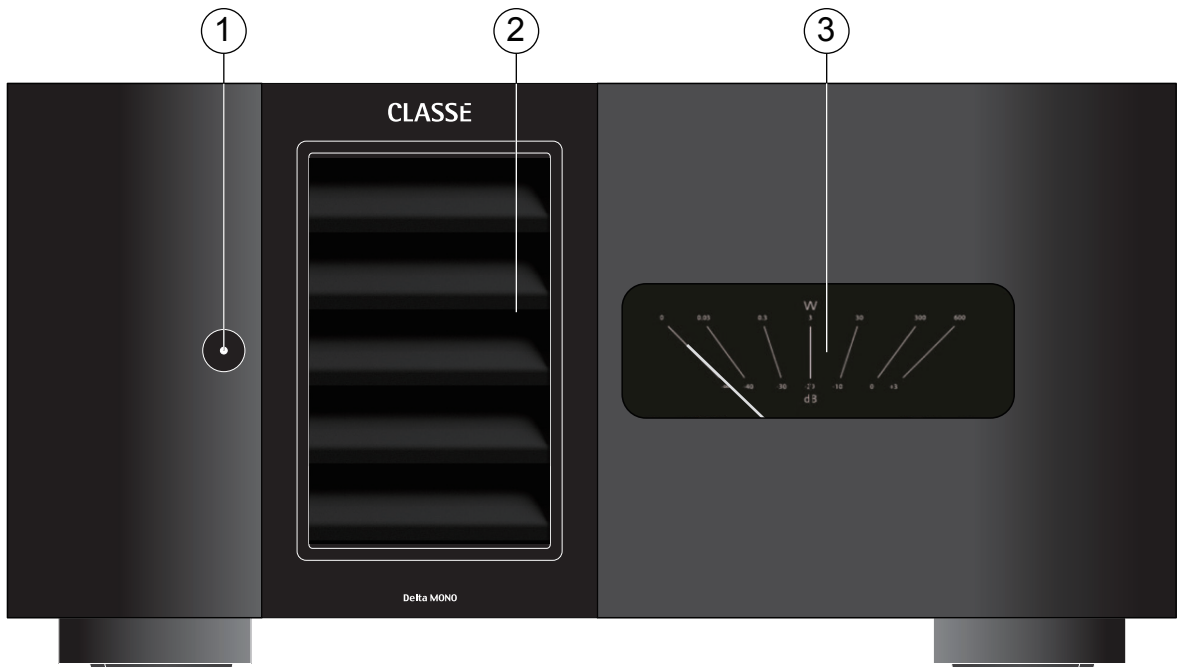

Front Panel

1 Standby/ON Button & Status Indicator LED

The front panel **Standby** button will toggle the amplifier between *operate*, its fully operational state, and a *standby* mode. (See also Wake on Network).

The current state of the amplifier is indicated by the **LED** status indicator in the **Standby** button. The state of this **LED** indicates the following:

- on (red) = *standby*
- slow flashing (white) = *initialization*
- on (white) = *operate*
- flashing (red) = *protection circuit(s) engaged*
- flashing (green) = *CAN identify mode*
- flashing (orange) = *error during update*

When in *standby*, the amplifier's gain stages are powered down. Only a small power supply and control circuit remain on, consuming relatively little power. Fortunately, since the output stages by their nature conduct a great deal of current, they warm up and sound their best very quickly.

If you are not going to use the amplifier for an extended period of time, we suggest you disconnect it from the AC mains.

Also, it is a good practice to physically disconnect any and all valuable electronics from the AC mains during electrical storms, as a lightning strike anywhere near your home can put a tremendous surge on the AC mains that can easily damage any piece of electronics, no matter how well designed and protected. The best protection in the case of severe electrical storms is to simply remove the electronics from any connection with the power grid.



Caution!

If you see the Standby LED indicator blinking red, please check that all external connections are cleanly made and secure. If no fault is immediately obvious, try to reset the amplifier by pressing and holding the standby button. If the unit does not reset or continues to enter protection mode, please call your authorized Classé dealer for assistance.

2 ICTunnel™ Air Intake

The Intelligent Cooling Tunnel removes heat from the amplifier by pulling cool air through the intake on the front panel. To ensure the proper operation of the cooling system, be careful to keep the area around the air intake on the front panel free of obstructions.

3 Output VU Meter

The output meter shows output power in Watts into an 8 ohm load and provides a good relative indication of output in dB. A good rule of thumb is that when the pointer is below/left of vertical the amplifier is operating in class A.

The backlight of the VU meter may be adjusted to three different brightness levels or turned off. To adjust the brightness level, with the amplifier in standby, press and hold the standby button for approximately 5 seconds. The backlight will begin cycling through its brightness levels. When the desired brightness is reached, release the button.

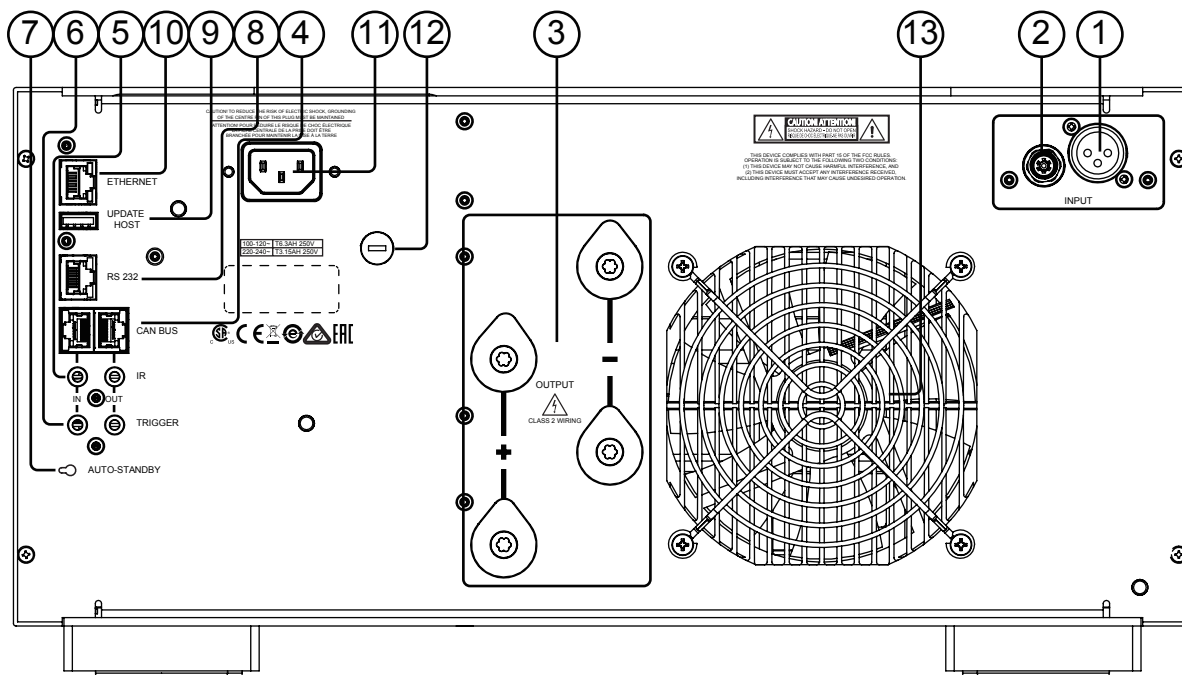

Rear Panel

The following descriptions are intended as a quick reference, should you have any questions about your new product. Please see the next section (entitled *Installation*) for specific advice on incorporating your new amplifier into your system.

1 Balanced (XLR) Input

Balanced audio interconnections were originally developed for the telephone and more recently have been used in the professional audio world for preserving the delicate nuances of extremely small microphone-level signals. For many years now, they have also been used by performance-oriented companies such as Classé to preserve every nuance of the finest audio recordings in your collection.

Technically, balanced audio interconnections provide two distinct benefits: they double the signal's strength as it travels from one component to the next, increasing the potential Signal-to-Noise ratio by 6 dB; they also do an excellent job of rejecting noise and interference that might otherwise be picked up between the components. If executed as in the Delta MONO with a high degree of symmetry between the inverting and non-inverting signal paths, balanced connections can offer the best performance. For this reason, we strongly recommend using the balanced analog interconnections between your Classé components wherever possible.

The pin assignments of these **XLR input connectors** are:

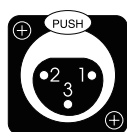

- Pin 1: Signal ground
- Pin 2: Signal + (non-inverting)
- Pin 3: Signal – (inverting)
- Connector ground lug: chassis ground

These pin assignments are consistent with the standard adopted by the Audio Engineering Society (AES14-1992).

If you are using your Classé power amplifier with a Classé preamplifier/processor, you're all set – just remove the supplied shorting pins (between Pins 1 and 3) from the amplifier's XLR connector(s), take standard balanced interconnect cables and plug them in.

If you are using another brand of preamplifier or processor, please refer to its operating manual to verify that the pin assignments of its output connectors correspond to those of your amplifier. If not, have your dealer obtain cables with the appropriate output pin connecting to the equivalent input pin.

2 Single-Ended (RCA) Input

Single-ended cables using **RCA** connectors are the most common form of analog connection used in consumer electronics. When implemented carefully and with use of high quality interconnecting cables, this standard can provide excellent performance. Classé has gone to extraordinary effort to ensure that the single-ended (RCA) inputs of your power amplifier perform exceptionally well.

When using single-ended (RCA) inputs: to reduce the potential to conduct noise, be sure to leave the shorting pins in place between pins 1 and 3 of the XLR connector.

3 Speaker Outputs

The Delta MONO is designed to accommodate the impedance range of all commercially available loudspeakers. Your dealer is in a good position to advise which and/or how many amplifiers are suitable for your particular loudspeakers.

To facilitate bi-wiring, two pairs of high-quality **five-way binding posts** are provided on the amplifier. These connectors are made of rhodium-plated copper and designed with a feature called Torque-Guard, which ensures the optimum contact pressure to mate with your speaker wire connector lugs without allowing the connector to be over-tightened. As you tighten them, they will reach the proper torque and therefore act like a torque wrench with click sounds indicating that the proper torque has been reached.

In practice, bi-wiring involves connecting two (preferably identical) sets of speaker cables between each amplifier channel and its corresponding loudspeaker. In many cases, the benefit is a subjectively improved level of clarity and detail from the speaker, as a result of being able to feed the two separate sections of its crossover and driver complement with identical, yet separate signals.

(Many high quality loudspeakers also offer two sets of connections on their speakers. Generally, one set of the connections on the loudspeaker feeds the portion of the speaker's crossover network that supplies the woofer with its signal; the other set of connections connects to the portion of the crossover that supplies the rest of the speaker with the midrange and high frequencies.)

Although the binding posts on your Classé amplifier will accept bare wire connections, we strongly recommend the use of high quality spade or hook lugs, crimped onto the ends of your speaker wires. Using high quality connectors will ensure that your speaker connections do not gradually deteriorate from fraying and oxidizing bare wires. It also helps prevent accidental short-circuits from poorly-terminated connections.

4 Classé CAN-Bus Control Ports

These **RJ-45** connectors are reserved for control and communication applications using a Classé implementation of the Controller Area Network (CAN) Bus specification. Refer to the **CAN-Bus** section located later in this manual for more information.

5 IR Input and Output

Your Classé amplifier includes two $\frac{1}{8}$ th-inch **mini mono-jacks** in order to support the IR remote controls that are ubiquitous today. IR commands exist for toggling the amplifier between *operate* and *standby*, as well as discrete command codes for either *operate* or *standby*. These codes may be used in “macros” for sophisticated remote control systems, facilitating the control of the amplifier in the larger context of a complete system.

Actually, this *IR Input and Output* description is a bit of a misnomer: the input supplied to these plugs is *electrical* in nature, not IR. It is obtained by using standard IR receivers, distribution amplifiers, and emitters (available from your dealer) to translate the remote’s flashes of infrared light into corresponding pulses of electricity. The big advantages here include being able to easily route the signals anywhere they might need to go, and the reliability of a solid electrical connection.

Since an IR distribution system such as your dealer may design for you usually must control many products, your amplifier includes both an IR input (for the control of this product) and an IR output (so as to pass along the same signal to the next product). This allows you to “daisy chain” your control wires from one product to the next.

The amplifier is designed to respond to IR commands of 5 Volts DC, with the tip of the mini-plugs defined to be “positive” relative to the shank of the plug.



6 DC Trigger Input and Output

Many audio/video preamplifiers can supply a DC control voltage to associated equipment in order to induce desired behavior. Your Classé amplifier can take advantage of these capabilities in order to be switched between *operate* and *standby* automatically, perhaps in concert with the preamp/processor itself.

Two $\frac{1}{8}$ th-inch **mini mono-jacks** provide this remote-controlled turn-on (that is, toggling between *operate* and *standby*) of the amplifier. These jacks provide a simple pass-through of the control voltage from one to the other, allowing you to “daisy-chain” a series of amplifiers quite easily.

The remote trigger will be operated by the presence of 5–12 Volts DC, with tip polarity as shown below:

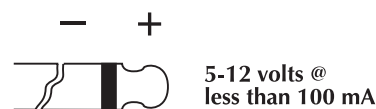

7 Auto Standby / Wake on Network

The Delta MONO employs power saving features to ensure that it consumes a minimal amount of power while not in use.

Auto Standby will switch the amplifier off if no audio signal is present for approximately 20 minutes (and if a DC trigger isn't overriding it).

The default mode is for the Auto Standby feature to be *disabled*. If you want this feature to be enabled, press the button to toggle it on. You will see a green LED through the hole (next to the button) light up. Please note that the Auto Standby toggle can only be executed when the unit is powered on.

The Delta MONO supports network-enabled control using Ethernet, RS-232 or CAN Bus interfaces. A low-power standby mode may be engaged by disabling something called **Wake on Network** mode.* With Wake on Network disabled, RS-232 and CAN Bus control will not be able to wake the amplifier from standby so DC trigger or front panel commands are required.

**Note that UKEC version units such as those sold in the European Union are shipped with Wake on Network mode disabled.*

To identify whether the Wake on Network feature is enabled or disabled and to change its state, use the following procedure:

Unplug the power cord from the amplifier and plug it back in after 10 seconds. With the amplifier in standby mode (= not powered on), press and hold the Auto Standby button while observing the front panel VU meter light.

The light will blink *once* to indicate that Wake on Network is disabled or *twice* to indicate it is enabled. To change the state, continue holding the button to cycle between disabled and enabled. For example, if you want Wake on Network *enabled*, release the button after the VU meter light blinks *twice*.

8 RS-232 Control Port

This **RJ-45 connector** is used for external RS-232 control of your amplifier by systems such as AMX[®], Crestron[™] and Control 4[™]. For more information, please contact your dealer and ask about home automation systems.

RJ-45 - DB9 female adaptor

If your RS-232 control system uses a cable with a male DB9 connector, you will need to buy or build an adaptor to convert the RJ-45 female to a DB9 female. Standard RJ45-to-DB9 female connectors come with RJ-45 pins and connections as below. Wire the DB9 adaptor according to this diagram and table.

RJ-45

Pin-1 = DSR
Pin-2 = DTR
Pin-3 = CTS
Pin-4 = GND
Pin-5 = RXD
Pin-6 = TXD
Pin-7 = N/C
Pin-8 = Power Input

DB9

Pin-1 = N/C
Pin-2 = RXD
Pin-3 = TXD
Pin-4 = DTR
Pin-5 = GND
Pin-6 = DSR
Pin-7 = N/C
Pin-8 = CTS
Pin-9 = Power Input

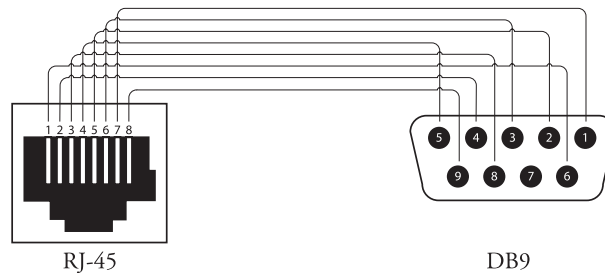

Remarks: The Cat 5 cable that plugs into this adaptor and then into the rear panel RJ-45 port must use pin-to-pin wiring (pin one to pin one, two to two and so on).

9 USB Port

The USB connector is used to host a USB stick for updating amplifier firmware, should that become necessary.

10 Ethernet Port

The Ethernet port allows control and update features when connected to a local network. It supports DHCP (dynamic host configuration protocol) which means that it will have an IP address automatically assigned.

If static IP addressing is required, it can be accomplished by creating a reservation table (see your router's settings page) based on the amplifier's MAC address printed on its serial number label (back-panel).

To perform firmware updates via the Ethernet port a network connection, web browser and the firmware file (*.bwu extension) is all that's required. In order to access the amplifier's web interface, the assigned IP address needs to be entered in the browser's address bar. Locate the IP address by looking at the connected devices table in your router's setup interface, or by using a network scanner app from a mobile device on the same network.

If a reservation for the amp has been assigned in the router's settings, then it will be the reserved IP address. Once the web page is loaded, please follow the instructions shown in the "Firmware" tab.

11 AC Mains Input (AC IN)

An IEC standard power cord (supplied) is used with the Delta MONO. Plug the cord into the **IEC receptacle** on the rear panel, and the other end into a suitable wall outlet.

12 AC Mains Fuse

Your Classé power amplifier has an **AC mains fuse**, accessible on the rear panel. If you suspect that your AC fuse has blown, disconnect your amplifier from the AC mains, as well as from its input connections and speaker connections, and refer to the appropriate item of the section entitled *Troubleshooting*.

13 ICTunnel™ Exhaust Port

The Intelligent Cooling Tunnel removes heat from the amplifier via the exhaust port on the rear. To ensure the proper operation of the cooling system, be careful to keep the area around the rear of the amplifier free of obstructions. See also the section on Ventilation

Do not open your amplifier. There are no user-serviceable parts within this product.



Danger!

Potentially dangerous voltages and current capabilities exist within your power amplifier, even when disconnected from AC mains. Do not attempt to open any portion of the amplifier's cabinet. There are no user-serviceable parts inside your power amplifier. All service of this product must be referred to a qualified Classé dealer or distributor.

Installation

Your new Classé amplifier is quite simple to set up and enjoy. Please follow the steps outlined below in order to safely set up and use your new amplifier.



Important:

It is always a good idea to power up your power amplifier(s) last, after everything else has been powered up and has stabilized.

Conversely, it is good practice to power the amplifier(s) down first when shutting down the system, as this prevents any transients from other components from getting through to your loudspeakers.

- 1. Unpack everything according to the included instructions.**
Be careful when doing so, as this amplifier is quite heavy.
- 2. Place your amplifier (be sure to read “Unpacking and Placement”) and connect it to the AC mains.** This includes deciding on the location, making sure you have adequate ventilation, and adequate clearance for all the wires behind the amplifier. Once accomplished, connect the amplifier directly to the AC mains. A high-performance power cord has been selected and supplied with your amplifier. Do not use extension cords, as most are not suitable for the current sometimes required by your amplifier.
- 3. Make your preamp/processor connections.**
With the amplifier in *standby* (or disconnected from the AC mains), using high quality interconnecting cables, make the appropriate connections with the balanced or single-ended connectors. Do NOT connect preamps/processors to both balanced and single-ended inputs at the same time. This could result in damage to the input circuitry which is not covered under warranty.

Make sure all the connections are snug, even if it means gently squeezing the outer shell of the RCA with pliers and reinserting it to tighten the connection.

- 4. Make your speaker connections.**
Make the connection between the output terminals of the amplifier and your loudspeakers, using high quality speaker wires.

Connect the black (–) terminals on the amplifier to the black (–) terminals on your speaker, and the red (+) terminals on the amplifier to the red (+) terminals on your speaker. If bi-wiring, run a total of four conductors between each amplifier channel and its corresponding loudspeaker: two separate +/- leads, one for the bass and the other for the mids and treble. Make sure that no wires cross between the red (+) and black (–) terminals, at either end.

The Delta MONO utilizes premium quality binding posts that provide an optimum torque feature which ensures the correct pressure or tightness of the connection while preventing damage that can result from over-tightening. Secure the speaker cables by tightening the binding posts until you hear the clicks indicating you've reached the proper torque for the connection.

5. Double-check all your connections.

We understand that this step sounds redundant, but it is worth the extra minute or two it might take just to ensure that all connections are correct and secure before plugging the power cables to the AC outlets.

6. Turn on all the other components in your system, and then turn on your amplifier.

It is always good practice to turn any power amplifier on last, and to turn it off first. Doing so prevents any turn-on/turn-off transients that might originate in other components from damaging your loudspeakers.

Your amplifier will reach thermal equilibrium in 10-15 minutes. This eliminates the need to keep the amplifier on for extended periods of time. If you plan to not use it for a while, it is best to keep it in standby.

CAN-Bus

CAN-Bus Classé's Controller Area Network, or CAN-Bus, allows communication and control between similarly featured Classé components. When the amplifier is connected with other CAN-Bus-equipped Classé components, the different elements in the system are in constant communication, creating a "global" network that delivers system wide status information and shared operational features, all through the preamp/processor's touchscreen display.

Note that some components will require a software update to recognize the Delta MONO on the CAN-Bus. Check the Classé website periodically for updates.

features CAN-Bus will allow a Classé touchscreen to:

- Display status information for every connected unit, including amplifiers which do not have a touchscreen display.
- Create a "PlayLink" that allows an SSP or Preamp to automatically switch to the correct input when a Delta series source component starts playback.
- Adjust the global system brightness.
- Configure the entire system to go in and out of standby at the touch of a button and also bring individual components in and out of standby.
- Mute any connected unit.

hardware setup

1 Classé CAN-Bus Equipped Products

Two or more Classé CAN-Bus equipped products are required, at least one of which must have a touchscreen display.

2 Category 5 Network Cables

These are ordinary network cables, commonly used for broadband Internet connections. They should be typical "straight through" cables not the "crossed over" type, and the total required will be one less than the total number of CAN-Bus equipped components in your system. Daisy chain the components from one to the next using these network cables.

3 CAN-Bus Terminator

A single CAN-Bus Terminator may be required. It is inserted into the CAN-Bus OUT connector of the last component in the CAN-Bus daisy chain. One is included in the box with your amplifier. They are also available for a small fee from your nearest Classé Customer Support Centre.

<https://classeaudio.com/contact/>

using CAN-Bus

CAN-Bus is controlled via the touchscreen of any Classé component that is so equipped. There is no master component, so Classé series systems where two or more units have a touchscreen can be controlled through any of the touchscreens. However, it is probably easiest to start using CAN-Bus through just one.

CAN-Bus is accessed by pressing the **menu** button on the face of the unit or remote, then the **status** button, followed by the **more** button (right arrow) in the upper right corner of the screen. The touchscreen will then display the **CAN-Bus devices** screen, which lists connected components by model & serial number.

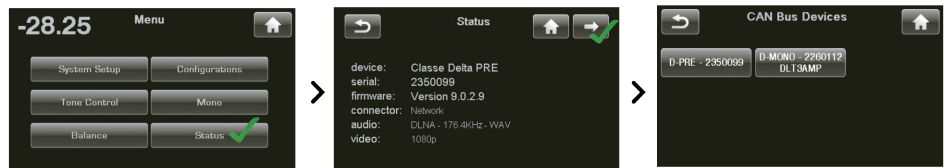

Selecting a unit on the CAN-Bus devices screen identifies it as the **target unit**. The front panel LED(s) or meter light of the target unit will start flashing (unless you choose the unit that you are using to access CAN-Bus).

Once you have chosen the target unit, the touch screen will list the CAN-Bus features available to it. Some CAN-Bus features are shared by all models, some are specific to individual models.

Make sure to exit the CAN-Bus pages before putting your unit(s) into Standby, otherwise the previously selected unit will continue to flash its front panel LED when powering up the next time.

CAN-Bus amp features

The following CAN-Bus features are available on the Delta MONO.

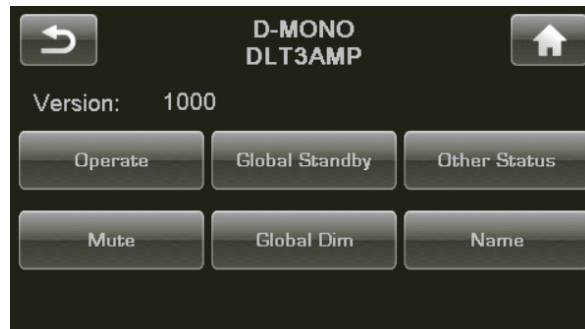

The model, name and firmware version number will be displayed on the CAN-Bus page of the targeted unit.

Operate The **Operate** button allows you to bring the target unit in and out of standby. This button will be disabled for the unit whose touchscreen you are using to access CAN-Bus.

Mute Engaging Mute will mute the output of the target unit.

Global Standby	By setting all your components to Global Standby you can bring your entire system in and out of standby by pressing the standby button of any unit or remote. All CAN-Bus software updates automatically set the updated unit to Global Standby. If you want a particular unit to be excluded from Global Standby, deselect Global Standby for that unit.
Global Dim	By setting all your components to Global Dim (referred to as Global Brightness in earlier models), you can adjust the touchscreen and LED brightness for your entire system by changing the brightness of a single touchscreen. All CAN-Bus software updates automatically set the updated unit to Global Dim. If you want a particular unit to be excluded from Global Dim, deselect Global Dim for that unit.
Other status	The Other Status screen displays information about the target unit's internal temperature sensors. Readings for Heatsink 1 & 2 are displayed in degrees Celsius. <i>Note: This feature is only available when the target amplifier is in operate mode.</i>
name	You can set the name which will appear next to the unit model name and facilitate the identification of units in large systems.
Event Log	Reserved for amplifiers, this feature records protection circuit events and can only be accessed when the target amplifier is in standby . <i>Note: For the amp to be put into standby while allowing the unit with the touchscreen to remain in operate mode, Global Standby for the amp must be deselected (not highlighted) so the amp can be manually put into standby.</i> The protection circuit shuts down the amplifier or channel if it overheats or if its output could damage your speakers. The Event Log details the circumstances surrounding the amp going into protection and should be referred to in situations that require the intervention of your dealer or Classé customer support. The Delta MONO Event Log can report the following events interpreted as follows: <ul style="list-style-type: none"> • DC Output — DC from the source has exceeded the amplifier's ability to correct for it. The amplifier will shut down to protect the loudspeaker. • Over Current — The peak current has exceeded the safe operating limit, i.e. a short circuit. • CBE — Comm Board Error. There has been an internal communication error. • Over Temp — The internal temperature has exceeded the safe operating limit. • Fan Failure — The fan has been disconnected or is unable to spin. Protection events are rare and generally occur due to issues that are external to the amp. They should be interpreted positively. The amp is doing what it's designed to do.

Care and Maintenance

To remove dust from the cabinet of your amplifier, use a feather duster or a lint-free soft cloth. To remove dirt and fingerprints, we recommend using a microfibre cloth and static free lens cleaner such as you would use for cleaning a flat panel display.

Special care should be taken to gently clean the meter lens to avoid marking it in any way.

Caution! DO NOT use paper towels as they may scratch the meter lens surface.



Caution!

At no time should liquid cleaners be applied directly to the amplifier, as direct application of liquids may result in damage to electronic components within the unit.

Troubleshooting

In general, you should refer any service problems to your Classé dealer. Before contacting your dealer, however, check to see if the problem is listed here.

1. No sound, and Standby LED is not lit.

- The amplifier is not plugged into the AC mains, or the AC mains are down (circuit breaker, fuse).
- A brown-out or short-term loss of power might require the internal microprocessor to be reset. Unplug the unit for at least 30 seconds and then plug it in again and try powering it up.
- The AC mains fuse is blown. See *Troubleshooting #4*, below (or contact your Classé dealer).
- The AC mains is out of range. Check the line voltage supplying the amplifier.

2. No sound, and Standby LED is blinking red.

- The protection circuitry has been engaged.
- Press and hold the standby button to reset the amplifier.
- If the amplifier does not reset or continues to go into protection mode, disconnect the amplifier from the AC mains, and disconnect all inputs and outputs.
- Try to power up the amplifier again, connecting it only to AC power. If the LED continues to blink, there is a fault condition in the amplifier itself and it should be disconnected and taken to your Classé dealer for service.
- If it powers up without any difficulty, first power it back down and reconnect only the inputs, then restart the amplifier. If it again powers up normally, there may be a problem such as shorted speaker leads. Check the connections to confirm there are no obvious shorts, then connect first one channel, followed by the other, to confirm either that there is no longer a shorted lead or if there is, which channel is shorted.

3. The amplifier keeps shutting off.

- If the shut down occurs after approximately 20 minutes being idle, it is likely that the Auto Standby power saving feature is enabled. With very low signal levels the amplifier may not reliably detect them, allowing Auto Standby to engage. To determine its state or disable Auto Standby, see the Auto Standby section of this manual.
- Make sure you are providing adequate ventilation to the amplifier and that the ambient room temperature is below 105°F (40°C).
- Run through the troubleshooting sequence outlined above (assuming the amplifier is going into its protection mode).
- The amplifier logs all protection circuit events--these are viewable on the touchscreen of a CAN-Bus connected Classé component or by your dealer on a PC using a special diagnostic program. Contact your dealer to assess the likely cause of the trouble.

4. The AC mains fuse is blown.

There is a specific troubleshooting procedure for a blown AC mains fuse, since this rare occurrence sometimes indicates a significant problem. Please use the following steps, in order:

- a. Disconnect your amplifier from the AC mains, as well as from its input connections and speaker connections, and remove the fuse cover on the rear of the unit.
- b. Check the fuse for continuity using an ohm meter, where the resistance should be essentially zero ohms. If the fuse is “open” or blown, replace it only with a fuse of the same type and rating (specified below). *Using any other type of fuse, particularly a larger-value fuse, can result in permanent damage to your amplifier.* If you are not comfortable replacing the fuse yourself, contact your Classé dealer for assistance.

Mains voltage:	100-120VAC
Fuse type:	IEC time lag, high breaking capacity
Rating:	6.3AH 250V

Mains voltage:	200-240VAC
Fuse type:	IEC time lag, high breaking capacity
Rating:	3.15AH 250V

- c. After replacing the fuse and fuse cover, reconnect the amplifier to the AC mains only and turn it on *without reconnecting either the inputs or the speaker wires*. If the fuse blows again, disconnect it from the AC mains and contact your Classé dealer for assistance.
- d. If everything seems fine, place the amplifier back into standby and carefully reconnect the input cable and power up the amplifier. If the fuse then blows (or the amplifier goes into protection), you may have a serious fault with your preamplifier/processor. Contact your Classé dealer.
- e. Finally, if everything is still fine, place the amplifier in *standby* and carefully reconnect the speaker wires. Check *both* ends of the speaker wires for possible short circuits. Then power up the amplifier again. If the amplifier remains functional (the fuse does not blow), then the original fuse probably blew in order to protect the amplifier from a large AC mains surge. If it blows again, contact your Classé dealer for assistance.

6. The Standby LED is solid red and the VU Meter LED shows a pulsing light pattern (*heartbeat*).

This is a normal reaction when the AC mains is abruptly interrupted or turned off, instead of using the normal Standby procedure. The pulsing LED shows a calibration period that lasts for 30 seconds after the AC Mains has been re-established.

Specifications

■ Frequency Response (50Ω Source Impedance)	1Hz – 650kHz, -3dB
■ Continuous Output power (at 1kHz, 0.1% THD+N)	(Pure Class-A Operation) 35W / 8Ω 300W / 8Ω 600W / 4Ω (With AC Line held constant) 1000W / 2Ω
■ Harmonic Distortion (500 kHz Bandwidth) (500kHz/25Vrms in 4Ω or 8Ω)	<0.0016% at 1kHz <0.0018% at 10kHz <0.0028% at 20kHz
■ Harmonic Distortion (90 kHz Bandwidth) (90kHz/25Vrms in 4Ω or 8Ω)	<0.0005% at 1kHz <0.0006% at 10kHz <0.0015% at 20kHz
■ Peak Output Voltage (Nominal AC Line)	(No Load) 148V peak-to-peak, 40Vrms (8Ω Load) 113V peak-to-peak, 40Vrms
■ Input Impedance	(Balanced/Single-Ended) 82kΩ
■ Voltage Gain	(at 1kHz, Balanced/Single-Ended) 29dB
■ Input Level for Nominal Output	(Balanced/Single-Ended) 1.74Vrms
■ Intermodulation Distortion (4Ω or 8Ω, Bal/SE)	SMPTE 4:1 <0.001% CCIF <0.002%
■ Signal-to-Noise Ratio (22kHz Bandwidth, 1.84Vrms input)	117dB (A-Weighted) 119.5dB
■ Slew Rate	72V/μs
■ Output Impedance (100 Hz / 1 kHz / 10 kHz)	0.010Ω / 0.011Ω / 0.015Ω
■ Damping Factor	(at 1kHz, ref 8Ω Load) 700
■ Standby Power Consumption (*20 mins after AC is applied)	(Wake-on-LAN disabled*) 0.22W (Wake-on-LAN enabled) 2.8W
■ Power Consumption	Rated (1/8 th into 4Ω) 5.4 A / 610VA (407W) Max. Power (300W into 8Ω) 715VA (500W)
■ Power Supply (The MONO is configured to one of these AC configurations)	100V- 50/60Hz 120V- 50/60Hz 230V- 50/60Hz

Note: Refer to the rear panel of the MONO for the configured voltage

- **Operating Temperature** 50-95 ° F (10-35 ° C)
- **Overall Dimensions**
 - (17.50") 444mm Width
 - (incl. connectors) (19.37") 492mm Depth
 - (incl. feet) (8.74") 222mm Height
- **Net Weight** (97.7lbs) 44.3kg
- **Shipping Weight** (111.6lbs) 50.6kg

All Tests performed unweighted using balanced inputs and 500kHz measurement bandwidth (except when specified otherwise). For purposes of improvement, specifications and design are subject to change without notice.

For more information, see your Classé dealer, or contact our Headquarters at:

Sound United, LLC
 One Viper Way
 Vista, CA 92081
 United States

Internet: <https://classeaudio.com>

Classé and the Classé logo are trademarks of Sound United, LLC. All rights reserved.
 AMX® is a registered trademark of AMX Corporation of Richardson, TX. All rights reserved.
 Crestron™ is a trademark of Crestron Electronics, Inc. of Rockleigh, NJ. All rights reserved.
 Control 4™ is a trademark of Control 4 Corporation of Saltlake City UT. All rights reserved.

Dimensions

Delta MONO

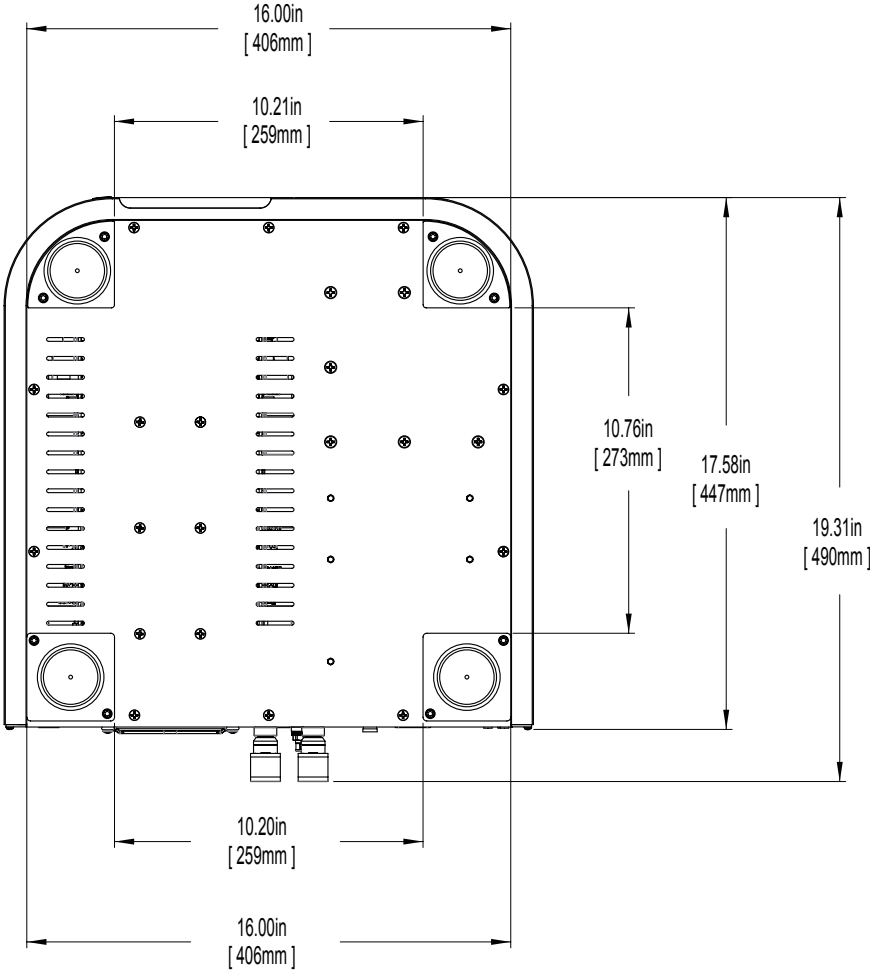
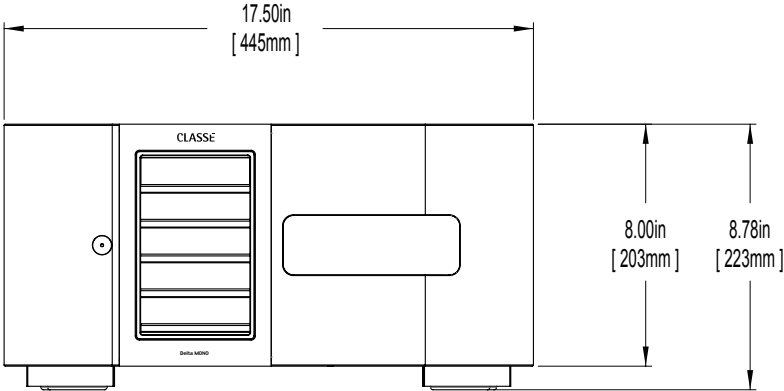

CLASSE

Classé
380, rue McArthur
Saint-Laurent, Québec
H4T 1X8 CANADA

Classé offers International Service and Support for its Products.
Please visit our Website to find up-to-date Contact Information.

<https://classeaudio.com>